



AVCOMM®

502W-IP67

Datasheet

Aiming to create better and safer working environments and life experiences through the products we deliver.



AVCOMM Technologies, Inc

www.avcomm.us

Email: info@avcomm.us

Phone: (713) 933-4534

Address: 333 West Loop North, Suite 460
Houston, TX 77024
United States

World First Outdoor Wireless 2.4G+5GHz MESH AP/Router

502W-IP67

Industrial 2.4G+5GHz Mesh WLAN AP/Router

The 502W-IP67 is the first outdoor WiFi AP / Router in the world to adopt the latest MESH WiFi technology for the growing demands of the industrial WiFi network. The MESH WiFi features Self Organizing Network that automatically selects and links different wireless networking devices together by the mesh topology. The 502W-IP67 significantly improves network coverage in different corners in an outdoor environment with advanced security. Equipped with a high-performance quad-core ARM processor, it can serve dual channels 5GHz IEEE 802.11ac Wave 2 and 2.4G 802.11n WLAN radio at the same time and reaches up to 866M+300Mbps high throughput. Advanced cybersecurity features such as OpenVPN, IPSec, L2TP and GRE tunnel are supported. The outdoor IP67 protection grade for -40~70°C wide operation temperature and PoE power input can be integrated easily into IoT applications.



Dual Bands Wireless LAN

- Quad Core ARM Processor
- Compatible with 802.11a/b/g/n
- Concurrent dual band 2.4 G+5GHz radio, up to 866Mbps + 300Mbps Bandwidth
- Dual Gigabit Ethernet ports in Router mode for WLAN/LAN to Eth-WAN routing

Qualcomm® Wi-Fi SON Technology

- Self-Healing auto rerouting through multi-hop (up to 4 layers and 8 hops)
- Self-Configuring Plug-and-play via Wireless network with AIAS utility
- Autonomous performance optimization (802.11k)*
- Interference management via band steering (802.11v)*
- Seamless roaming (802.11r)*
- Self-defending (Round-the-clock security)*

Enhanced Cyber Security & Redundancy

- Support Firewall for inbound/outbound traffic
- OpenVPN (server/client), IPsec for secure remote connection
- IPSec performance with 256-bit encryption is 150Mbps
- Support L2TP with PPP, PAP, CHAP(LCP, IPCP)
- * Support GRE tunnel
- HTTPs/SSH secure login
- Support TACACS+ multi-user authentication for privileged user management

Management Features

- Various configuration paths, including Web GUI, Telnet, LAN Utility (AIAS) and ANMS
- Support First login password management
- Web GUI for Wireless LAN Setting, Radio On/Off, Band and Frequency selection, SSID/Multiple SSID, SSID Broadcast On/Off
- 1:1 NAT, port forwarding for local traffic protection
- Support SNMPv3 and entity-MIB (RFC4133), MIB II (RFC1213)
- NTP v3 time management

Outdoor IoT Application

- Outdoor IP67 Production Design
- Effective heat dissipation design for operating in -40~70°C environments
- Power Input 802.3af PD by Industrial PoE switch as a complete wire/wireless solution

Cloud Management Service*

- Support Amazon AWS & Microsoft Azure cloud service
- Support private cloud service
- Interactive monitoring dashboard and map shows the status, signal strength, location etc.

✓ Self-Healing Mesh Technology

- Eliminate network bottleneck
- Auto rerouting through multi-hop
- Interference management (band steering)*
- Airtime fairness*
- Seamless roaming*

*By Request

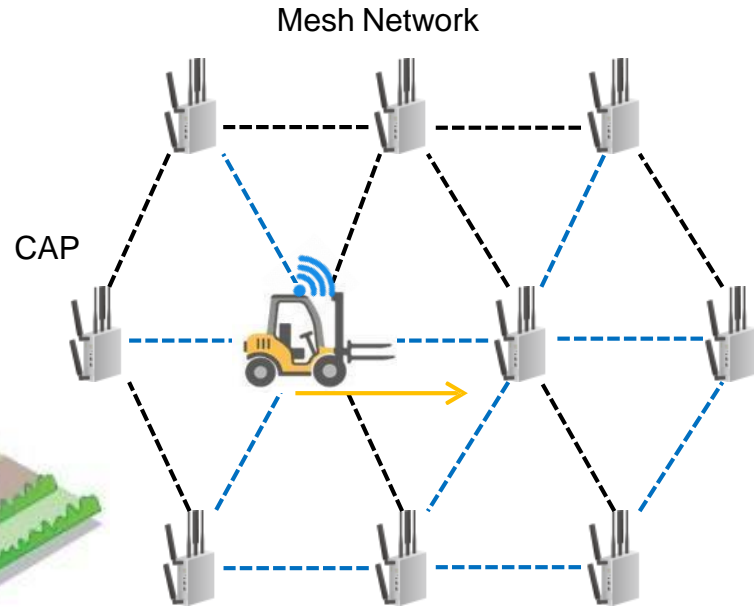

✓ Self-Configuring by AIAS Utility

- Simple configuration with 3 steps
 1. Select a CAP (Central AP)
 2. Auto discovery RE (Range Extender)
 3. Group Mesh setting
- Group Mesh SSID and WPA PSK setting
- Mesh status (signal, channel, uplink) *

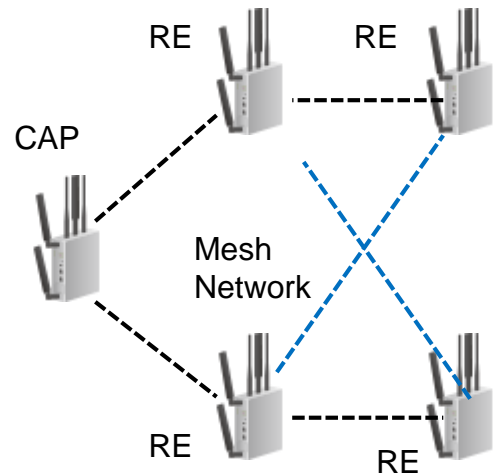

1 Select a CAP



2 Auto Discovery RE



3 Group Mesh Setting

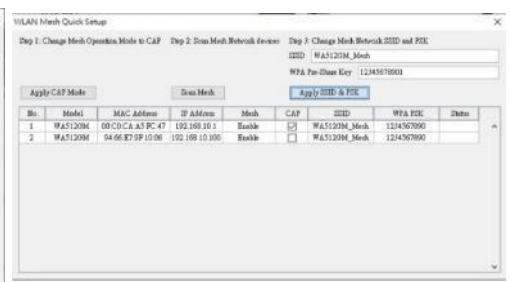



Ordering Information

Model Name	Description
502W-IP67	Industrial wireless AP/ router, compatible with 802.11a/b/g/n, dual-band 2.4g +5GHz concurrent, 2 RJ45 Ports 10/100 Base-T(X), Auto-MDI/MDIX, Wireless Mesh System, -40°C~85°C, IP30, DIN-Rail, metal case
502MW-IP67	Industrial wireless AP/ router, Mesh WiFi, compatible with 802.11a/b/g/n, dual-band 2.4g +5GHz concurrent, 2 RJ45 Ports 10/100 Base-T(X), Auto-MDI/MDIX, Wireless Mesh System, -40°C~85°C, IP30, DIN-Rail, metal case

Technology	
Standard	IEEE 802.11ac wireless local area network (WLAN), Backward support 802.11n/g/a/b Wireless LAN
	IEEE 802.3 10Base-T Ethernet
	IEEE 802.3u 100Base-TX Fast Ethernet
	IEEE 802.3ab 1000Base-T Gigabit Ethernet Copper
	IEEE 802.3af PoE
Interface	
Ethernet Port	1x 10/100/1000MBase-T Gigabit WAN PoE (P.D) port, RJ45 Water-proof cable gland 1x 10/100/1000MBase-T Gigabit LAN RJ45 Water-proof cable gland
System LED + Reset	Water-proof cable gland, with 1x Power 1x 2.4G 1x 5G 1x Reset button
SMA Socket	2x N-type female
USB	1x USB, type A water-proof cable gland
Power Input	802.3af PD
WLAN Properties	
Processor	Quad-Core CPU, 4x ARM Cortex A7 at 716.8MHz
Standard	Dual Band 2x2 2.4GHz 802.11n + 2x2 5GHz 802.11ac Radio IEEE 802.11ac/a/b/g/n wave2 MU-MIMO 802.11ac: OFDM (BPSK, QPSK, 16-QAM, 64-QAM, 256-QAM)
Data Rate	802.11ac: MCS0 ~ 9, max. 866Mbps 802.11b: 11Mbps / 802.11a/g: 54Mbps / 802.11n: MCS0 ~ 15, max. 300Mbps Check detail TX/RX information in User Manual
Frequency	ISM Band, 2.4GHz: 2.412GHz ~ 2.472GHz 5GHz: 5.180MHz ~ 5.240MHz, 5.745 ~ 5.825MHz(Band 1,4) 802.11ac 80MHz@5210MHz/5770MHz 2x SMA connector for simultaneous dual bands concurrent
MIMO	2.4/5GHz: 2T2R MU-MIMO DBDC (Dual Band Dual Concurrent)
Max. E.I.R.P.	≤20db@2.4G, ≤23db@5G B1, compliant with CE request
Power Requirement	
Input Voltage	IEEE 802.3af PD Powered Device
Power Consumption	9W full traffic, suggest to reserve 15% tolerance
Antenna	
WLAN Waterproof Antenna	Frequency: 2400~2500/ 5150~5850 MHz
	Peak Gain(max.): 2.4GHz: 4.35 dBi, 5GHz: 8.16dBi@Band 1, 6.87dBi@Band 4
	Direction: Omni
	Connector: N Type Male
	Dimension: 187xΦ20 mm
Software	
Management	CGI WebGUI, Command Line Interface (CLI), IPv4/IPv6*, Telnet, SNMP v1/v2c/v3, DDNS*, DHCP server/client, DHCP Relay*, TFTP, FTP(active/passive)*, System Log, SMTP*, Proxy ARP, DNS (client/proxy) , PPPOE*
MESH Wi-Fi*	Qualcomm Wi-Fi SON Technology, Self-healing by auto rerouting through multi-hop, Self-configuring Plug-and-play via AIAS, Mesh SSID/Password/Gateway, Mesh status (signal/channel/uplink)

Traffic Management	Traffic shaping, Flow Control*
Security	IEEE 802.1X/RADIUS, TLS v1.2, HTTPs/SSH, First login password management WLAN AP Security: Share Key, WPA/WPA2-PSK(Pre-Shared Key), WPA/WPA2 Enterprise Encryption: 64/128-bit WEP(Wired Equivalent Privacy), TKIP(WPA-PSK), AES(WPA2-PSK), MAC Filter*
Advanced Security	TACACS+, Mutli-user authentication
Time Management	NTP, SNTP
WAN/Routing/NAT/Firewall/ VPN	Routing: RIPv2, OSPFv2, VRRPv2* NAT: 1-1 NAT, NATP(SNAT/DNAT), Port Forwarding, DMZ Firewall: Stateful Inspection firewall, DMZ, IP/Port Filter, MAC ACL* VPN: IPSec, OpenVPN, L2TP, PPTP*, GRE*, >150Mbps IPSec Performance @256-bit encryption, DMVPN*, NHRP*, mGRE* Wireless WAN for LAN to Wireless WAN NAT
Seamless Roaming	Up to 100ms
IIoT Industrial Protocol	MQTTs, CoAP*, RESTful API*
Private Cloud	ATMS™, ATMS™ OTA
Public Cloud	AWS Agent*, Azure Agent*
MIB	MIB-II, Entity MIB, AVCOMM Private MIB
Utility	AIAS, ANMS, Ping, Traceroute
WLAN Configuration	WLAN Basic Settings: Radio on/off, 2.4G 11n/5G 11ac Band and Frequency selection, SSID/Multi-SSID configuration, SSID broadcast, Max. Output Power and Data Rate and advanced WLAN settings. Operation mode: Wireless AP, Wireless Client, WDS AP, WDS Client or MESH
Mechanical	
Installation	Ceiling/Wall/Pole mount
Enclosure Material	Steel Metal
Dimension	239mm(H) x 269mm(H) x 68mm(D)
Ingress Protection	IP67
Weight	≈2.4Kg
Environmental	
Operating Temperature & Humidity	-40°C~70°C (PD mode) 5%~95% Non- Condensing Note: Power the device by Industrial PoE Switch for high temperature environment.
Storage Temperature	-40°C~85°C
MTBF	>2,000,000 hours at 40° full cycle
Warranty	3 years
Attached PoE Injector	Input: 90~264Vac, 47~63Hz, Max. 0.55A Output: Passive 48V, 500mA (RJ45 Output Pin 4/5: V+, Pin 7/8: V-) Operating Temperature: 0~40°C Storage Temperature: -20~85°C
Approval	
CE	CE RED Compliance Safety: IEC/EN60950-1 EN 55032/55035/EN51000-3-2/EN61000-3-3 EN 301 489-1/17 EN 300 328/EN 301 893/EN 300 400 EN 62311 MPE
FCC	EMC: Part 15B
Safety	IEC/EN 62368-1, UL62368-1



function interface

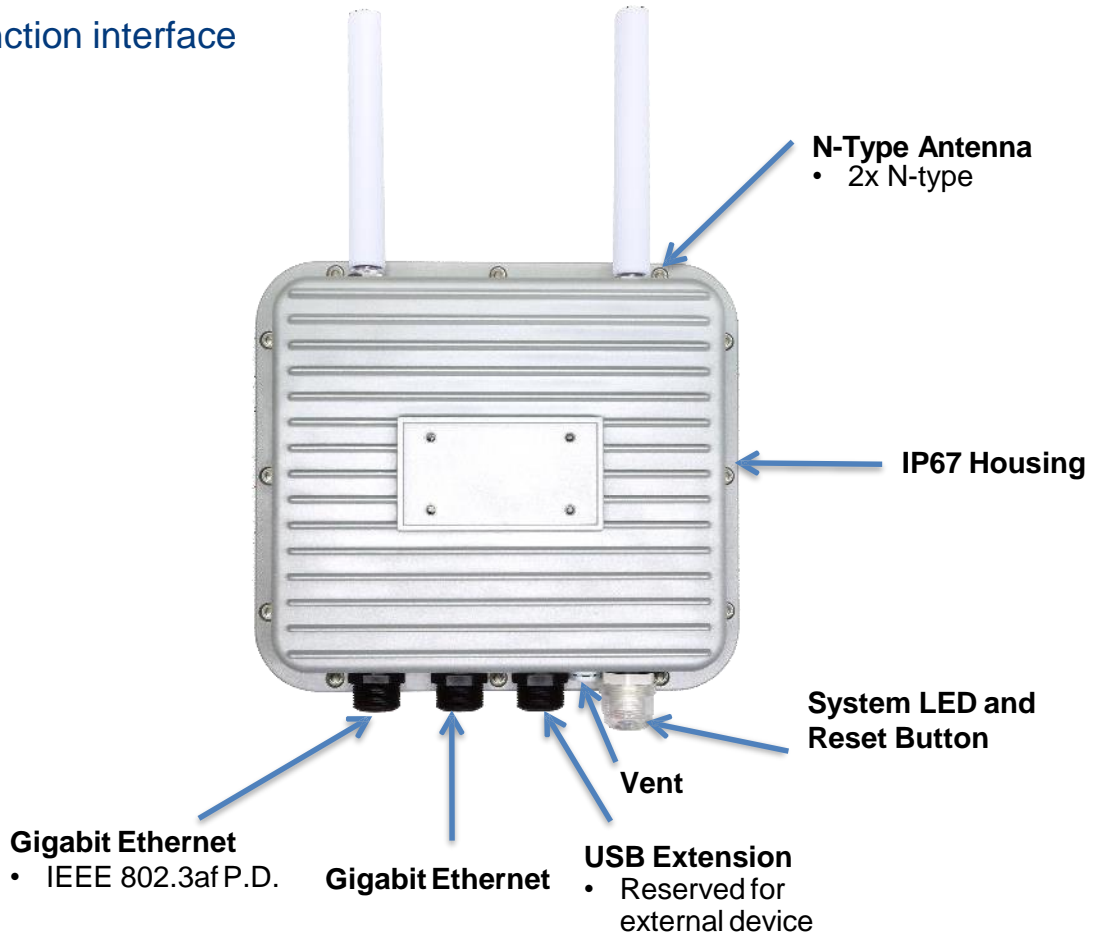

Installation dimensions

