



Quick Installation Guide

Industrial 28G L2+/L3 Rackmount Managed Ethernet Switch 8028GX8-AC2

www.avcomm.us

Overview

8028GX8 is an industrial grade rackmount 28G switch with 20 Giga copper ports, 4 Giga combo ports and 4 100M/1G fiber SFP slots. Rugged design, cyber security features and high EMC immunity makes the 8028GX8 an ideal solution for industrial control room, roadside traffic control, industrial IoT, industrial Surveillance applications.

Model Name	Description
8028GX8-AC2	Industrial 28G L2+ Managed Ethernet Switch, 20GT+4Gc+4GF, 2x AC110/220V input
8028GX8-L3-AC2	Industrial 28G L3 Managed Ethernet Switch, 20GT+4Gc+4GF, AC110/220V input

Package Checklist

- 1 x Product Unit
- 1 or 2 x Power Cord (AC model only, EU or US type)
- 1 x Quick Installation Guide

Optional Accessory (for detailed information please refer to the Datasheet):

- 1 Gbps SFP Transceiver

Installation Procedure

Installing in a Rack

Refer to the illustrations below; user can install the device in most standard 19-inch (48.3-cm) racks. For RS628/428 2 power series, user should use the 4 of supplied screws to attach a mounting bracket on each side of device first.

- Insert and tighten two screws through each of the mounting brackets.

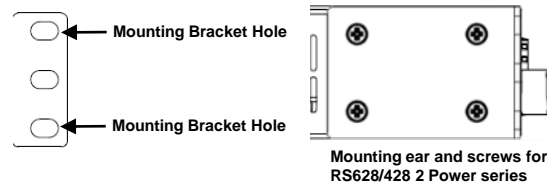

Wiring the Digital Input

To wire the DI on the Terminal block, use screwdriver to loosen screws, insert the positive and negative wires into the DI+ and DI- contact and then tighten screws after the DI wire is connected. High: 11~30V, Low: 0~10V.

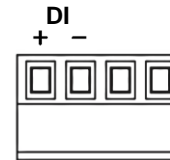

Wiring the Relay Output (Alarm)

The relay output of the 2-pin terminal block connector are used to detect user-configured events. The two wires attached to the fault contacts form a close circuit when a user-configured event is triggered. If a user-configured event does not occur, the fault circuit remains open. The spec. of DO is 0.5A/24VDC.

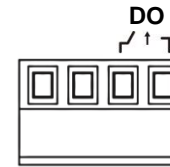

Wiring the Power Input

Connect the attached power to the AC or DC power input connector, the available AC power input range is from 90-264 VAC while the DC power input range is 18~72VDC.

Grounding Screw

For avoiding system damage by noise or electric shock, establish a direct connection between the ground screw and the grounding surface prior to connecting devices. At the AC power input, the 3 pin include V+, V- and GND. For DC version, the grounding screw is on the right side of DC power connector. The GND pin must be connected to the earth ground.

USB Port

Use the USB port in order to save or restore the configuration and upload the firmware upgrade file.

For further configurations, please refer to User Manual.

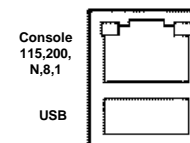

Combo Port Mode

The device supports 4 Combo ports and allow user to configure 3 types of port modes in the following path.

Ethernet Port -> Port Setting -> Port Mode
Select the Port Mode type and press "Submit". After submitted, Reboot the system to activate the new setting.

For further configurations, please refer to User Manual.

Port Mode	COMBO Port 21-24
20GbE Copper + 8 GbE Fiber (Default)	4 x Fiber
24GbE Copper + 4 GbE Fiber	4 x Copper
22GbE Copper + 6 GbE Fiber	2 x Copper+2 x Fiber

Appearance

Front view

8028GX8-AC2

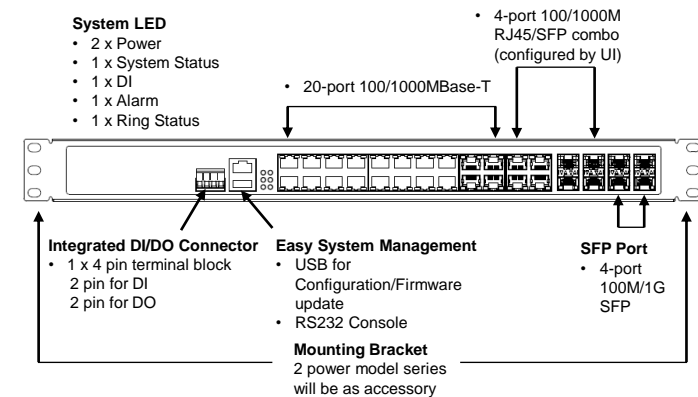

Rear view

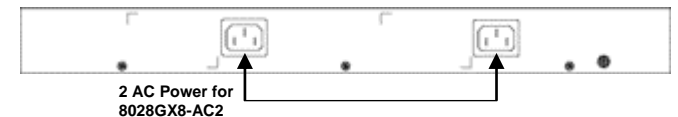

· LED Indication

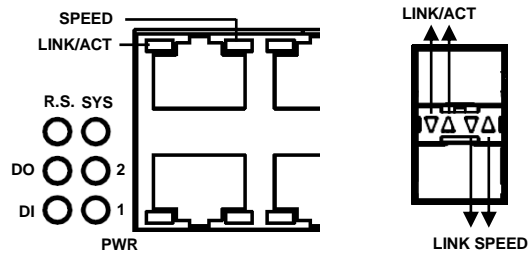

LED	Status	Description
PWR	Green On	Power is On
	Off	No Power
System LED	Green On	Ready
	Green Blinking	Firmware Updating
	Off	Not Ready
Ring LED	Green On	Not Owner/Normal
	Green Blinking	Owner/Normal
	Amber On	Abnormal
	Amber Blinking	Ring Port Fail
	Off	Ring is disabled
Alarm (DO)	Red On	Any failures in port link, ping, power, DO and DI State by SW control
	Off	No failure occurs
Digital Input (DI)	Green On	Detected Digital Input
	Off	No Digital Input
Giga Ethernet (Port1-24)	Green On	Links established
	Green Blinking	Packets transmitting/receiving
	Green Off	Link is inactive
	Amber On	Link Speed 1000M
	Amber Off	Link speed 10/100M
SFP Port (Port 21-28)	Green On	Links established
	Green Blinking	Packets transmitting/receiving
	Green Off	Link is inactive
	Amber On	Link Speed 1000M
	Amber Off	Link speed 10/100M

· Safety Precautions

- Keep DC power off before connecting to the terminal block connectors and ensure all connections are secure established.
- Do make sure that models connect to the corresponding supply voltage. The device is to be supplied by Limited Power Supply. The relay contact supports 0.5 A current, DC 24V.
- The DIN Rail should comply with DIN EN50022 standard. Using wrong DIN rail may cause unsafe installation.
- **Do not touch the surface of the switch while it is performing in the high temperature environment!**

· Management

This device supports both in-band and out-of-band network management. The user can either configure the device through the user-friendly Web/HTTPS management or remotely manage the device through the network by console management or Telnet/SSH.

1. **Web management:** Before start, confirm that device is properly connected in the network and that each PC in this network can access the router through the web browser (Google Chrome, Internet Explorer, Mozilla Firefox).
 - Type <http://192.168.10.1/> in the address bar (Default IP address is <http://192.168.10.1/>)
 - Enter the username and password in Login screen and click Login. The default username and password are **admin**.
 - You are required to change your password at first login. the welcome page of the web-based management interface will pop up when password is changed.
 - On the left side listed software features, and on the right side are available settings.
- ◆ To link with the device, please make sure that the IP Address of the PC is located in the same subnet (**192.168.10.x**).
2. **Console management (using RS232 Port):**
 - Connect console cable between your PC and the device.
 - Start -> Program -> Accessories -> Communication -> Hyper Terminal.
 - Give a name to a new console connection.
 - Choose the COM name and select correct serial settings: Baud Rate: 115200 / Parity: None / Data Bit: 8 / Stop Bit: 1
 - After connected, Key in the **New** user name and password in login screen while first Login. (The default user name and password in elder firmware is *admin/admin*. Try this while you don't see New user name/password prompt while first login.)
 - Follow the User Manual to configure the software features.
3. **Telnet/SSH management:** The router can be connected by Telnet and the command-lines. Steps to open Telnet connection to the router are as follow:
 - Start -> Open Command prompt ->Enter
 - Type the Telnet 192.168.10.1 (or the IP address of the switch). And then press Enter.

SSH (Secure Shell)

The router supports SSH console and can be connected via command-line interface access remotely. SSH connection can secure all the configuration commands that sent to the switch.

SSH Client

There are many free, sharewares, trials or charged SSH clients you can find on the internet.

- ◆ **For further feature configurations, please refer to User Manual.**

· Support

At AVCOMM, you can use the online service forms to **request the support**. The submitted forms are stored in server for AVCOMM team member to assign tasks and monitor the status of your service. Please feel free to write to info@avcomm.us if you encounter any problems.

· Warranty

5-year Global warranty are available for AVCOMM products assuring our customers that the products shall remain free from defects in workmanship or materials and conform in all material respects to AVCOMM specifications, or purchasers supplied and accepted specifications. The warranty is limited to the repair and/or replacement, at AVCOMM sole discretion, of the defective product during its warranty period. The customer must obtain a Return Merchandise Authorization (RMA) approval code prior to returning the defective Product to AVCOMM for service. The customer agrees to prepay shipping charges, to use the original shipping package or equivalent, and to ensure the product or assume the risk of loss or damage in transit. repaired or replaced products are warranted for ninety (90) days from the date of repair or replacement, or for the remainder of the original product's warranty period, whichever is longer.

· Disclaimer

AVCOMM reserves the right to make changes to this QIG or to the product hardware at any time without notice. It is the user's responsibility to determine whether there have been any such updates or amendments herein.

Defects, malfunctions, or failures of the warranted Product(s) caused by damage resulting from unforeseeable incidents (such as lightings, floods, fire, etc.), environmental and atmospheric disturbances, other external forces such as power line disturbances and surge, host computer malfunction and virus, incorrect power input, or incorrect cabling, incorrect grounding and damages caused by misuse, abuse and unauthorized alteration or repair are not warranted.