



## Quick Installation Guide

### Industrial 28G L2+/L3 Rackmount Managed PoE+ Ethernet Switch 6028GX8-POE

www.avcomm.us

#### Overview

6028GX8 is an industrial grade rackmount 28G switch with max. 24 Giga PoE+ ports, 4 Giga combo ports and 4x100M/1G fiber SFP ports, support max. 8 fiber Giga ports help to link more field switches with long distance fiber connections. The 24 full giga PoE+ ports, AC plus 2 DC inputs enhance the overall throughput and power delivery capacities. Rugged design and high EMC immunity makes 6028GX8 an ideal solution for industrial Critical Surveillance applications.

Model Name	Description
<b>6028GX8-PoE-AC2</b>	28-Port Industrial Fully Managed POE Switch, 20 RJ45 10/100/1000BaseT(X), 24 x 802.3af/at PoE, Auto Negotiation, 4 x 100/1000M 802.3af/at PoE RJ45/SFP Combo (4 Copper/4 fiber or 2 copper+2 fiber), 4 SFP Slots 1000BaseSFP+, Support POE/POE+
<b>6028GX8-POE-AC-DC2</b>	28-Port Industrial Fully Managed POE Switch, 20 RJ45 10/100/1000BaseT(X), 24 x 802.3af/at PoE, Auto Negotiation, 4 x 100/1000M 802.3af/at PoE RJ45/SFP Combo (4 Copper/4 fiber or 2 copper+2 fiber), 4 SFP Slots 1000BaseSFP+, Support POE/POE+
	<i>Note: Please contact AVCOMM Sales. *AC with higher PoE Budget by Request. *2DC/2AC Version By Request *Other type plug of Power Cord by Request</i>

#### Package Checklist

- 1 x Product Unit
- 1 x Power Cord (EU or US type)
- 1 x Quick Installation Guide

*Optional Accessory (for detailed information please refer to the Datasheet):*

- 1 Gbps SFP Transceiver

#### Installation Procedure

##### Installing in a Rack

Refer to the illustrations below; user can install the device in most standard 19-inch (48.3-cm) racks. For RS628/428 2 power series, user should use the 4 of supplied screws to attach a mounting bracket on each side of device first.

- Insert and tighten two screws through each of the mounting brackets.

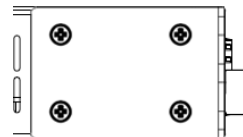

##### Wiring the Digital Input

To wire the DI on the Terminal block, use screwdriver to loosen screws, insert the positive and negative wires into the DI+ and DI- contact and then tighten screws after the DI wire is connected. High: 11~30V, Low: 0~10V.

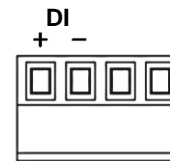

##### Wiring the Relay Output (Alarm)

The relay output of the 2-pin terminal block connector are used to detect user-configured events. The two wires attached to the fault contacts form a close circuit when a user-configured event is triggered. If a user-configured event does not occur, the fault circuit remains open. The spec. of DO is 0.5A/24VDC.

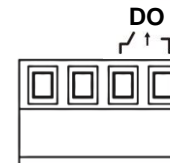

##### Wiring the Power Input

Connect the attached power to the AC or DC power input connector, the available AC power input range is from 90-264 VAC while the DC power input is 54VDC.

##### Grounding Screw

For avoiding system damage by noise or electric shock, establish a direct connection between the ground screw and the grounding surface prior to connecting devices. At the AC power input, the 3 pin include V+, V- and GND. For DC version, the grounding screw is on the right side of DC power connector. The GND pin must be connected to the earth ground.

##### USB Port

Use the USB port in order to save or restore the configuration and upload the firmware upgrade file. For further configurations, please refer to User Manual.

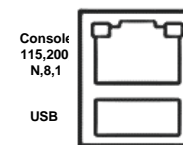

#### Combo Port Mode

The device supports 4 Combo ports and allow user to configure 3 types of port modes in the following path.

Ethernet Port -> Port Setting -> Port Mode  
Select the Port Mode type and press "Submit". After submitted, Reboot the system to activate the new setting.

For further configurations, please refer to User Manual.

Port Mode	COMBO Port 21-24
20GbE Copper + 8 GbE Fiber (Default)	4 x Fiber
24GbE Copper + 4 GbE Fiber	4 x Copper
22GbE Copper + 6 GbE Fiber	2 x Copper+2 x Fiber

#### Appearance

##### Front Panel Side

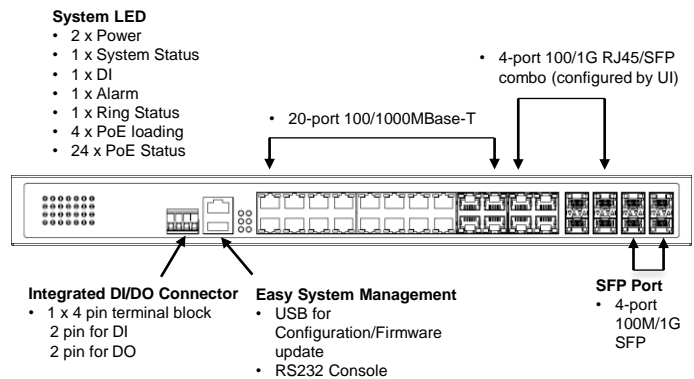

##### Back Panel Side

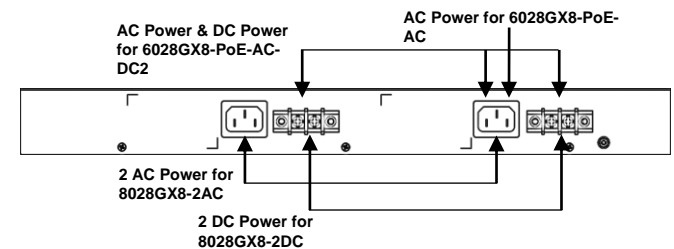

#### LED Indication

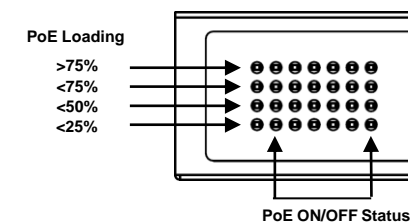

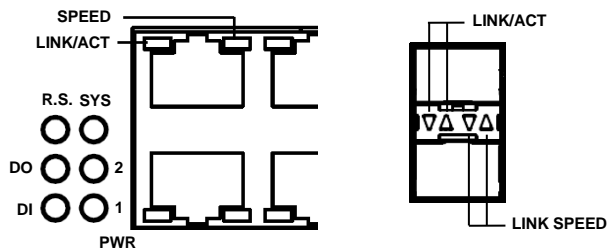

LED	Status	Description
PoE Loading	Green On	PoE loading is below than 25% or 50%
	Amber On	PoE loading is between 51% to 75%
	Red On	PoE loading is higher than 75%
PoE LED 1~24	Amber On	PoE delivering in progress
	Amber Off	PoE is disabled
PWR	Green On	Power is On
	Off	No Power
System LED	Green On	Ready
	Green Blinking	Firmware Updating
	Off	Not Ready
Ring LED	Green On	Not Owner/Normal
	Green Blinking	Owner/Normal
	Amber On	Abnormal
	Amber Blinking	Ring Port Fail
	Off	Ring is disabled
Alarm (DO)	Red On	Any failures in port link, ping, power, DO and DI State by SW control
	Off	No failure occurs
Digital Input (DI)	Green On	Detected Digital Input
	Off	No Digital Input
Giga Ethernet (Port1-24)	Green On	Links established
	Green Blinking	Packets transmitting/receiving
	Green Off	Link is inactive
	Amber On	Link Speed 1000M
	Amber Off	Link speed 10/100M
SFP Port (Port 21-28)	Green On	Links established
	Green Blinking	Packets transmitting/receiving
	Green Off	Link is inactive
	Amber On	Link Speed 1000M
	Amber Off	Link speed 10/100M

## · Safety Precautions

- **Restricted Access Location:** The device is intended for installation only in a Server Room or Computer Room where both these conditions apply:
  - access can only be gained by service persons or by users who have been instructed about the reasons for the restrictions applied to the location and about any precautions that shall be taken; and
  - access is through the use of a tool or lock and key, or other means of security, and is controlled by the authority responsible for the location.
- To remove the AC power from the system, unplug each AC power cord from the wall outlet or power supply. The power cord(s) is considered the disconnect device to the main (AC) power. The socket outlet that the system plugs into shall be installed near the equipment and shall be easily accessible.

## · Management

This device supports both in-band and out-of-band network management. The user can either configure the device through the user friendly Web/HTTPS management or remotely manage the device through the network by console management or Telnet/SSH.

1. Preparation for **Web management**: First of all, verify that device is properly installed in the network and that every PC of this network can access the switch through the web browser (Google Chrome, Internet Explorer, Mozilla Firefox).
  - Type **http://IP address** in your browser (the default IP address is **http://192.168.10.1**)
  - Key in the user name and password in login screen. The default user name is **admin**. The system will remind you to set new password in the first login.
  - After you click OK, the Welcome page of the web-based management interface will appear.
  - On the left side you can see the list of software features, on the right side – available settings.
- ◆ To link with the device, please make sure that the IP Address of the PC is located in the same subnet (**192.168.10.x**).
2. Preparation for **Console management (using RS232 Port)**:
  - Connect console cable between your PC and the device.
  - Start -> Program -> Accessories -> Communication -> Hyper Terminal.
  - Give a name to a new console connection.
  - Choose the COM name and select correct serial settings: Baud Rate: 115200 / Parity: None / Data Bit: 8 / Stop Bit: 1
  - After connected, type the username **admin** to login. The system will remind you to set new password in the first login.
  - Follow the User Manual to configure the software features.
3. Preparation for **Telnet/SSH management**: You can connect to the device by Telnet and the command lines are the same as what you see by console management. Below are the steps to open Telnet connection to the switch.
  - Start -> Control Panel -> Programs -> Select "Turn Windows features on or off" -> Check "Telnet Client" box -> OK.
  - Start -> Open Command prompt -> Enter
  - Type the Telnet 192.168.10.1 (or the IP address of the switch). And then press Enter.

## SSH (Secure Shell)

The device also supports SSH console. You can remotely connect to the switch to access command line interface. The SSH connection can secure all the configuration commands you sent to the switch. SSH is a client/server architecture while the Switch is the SSH server. When you want to make SSH connection with the switch, you should download the SSH client tool first.

## SSH Client

There are many free, sharewares, trials or charged SSH clients you can find on the internet.

- ◆ **For further feature configurations, please refer to User Manual.**

## · Support

At AVCOMM, you can use the online service forms to **request the support**. The submitted forms are stored in server for AVCOMM team member to assign tasks and monitor the status of your service. Please feel free to write to [info@avcomm.us](mailto:info@avcomm.us) if you encounter any problems.

## · Warranty

**5-year Global warranties** are available for AVCOMM products assuring our customers that the products shall remain free from defects in workmanship or materials and conform in all material respects to AVCOMM specifications, or Purchaser's supplied and accepted specifications. The warranty is limited to the repair and/or replacement, at AVCOMM sole discretion, of the defective product during its warranty period. The customer must obtain a **Return Merchandise Authorization (RMA)** approval code prior to returning the defective Product to AVCOMM for service. The customer agrees to prepay shipping charges, to use the original shipping container or equivalent, and to insure the Product or assume the risk of loss or damage in transit. Repaired or replaced products are warranted for ninety (90) days from the date of repair or replacement, or for the remainder of the original product's warranty period, whichever is longer.

## · Disclaimer

AVCOMM reserves the right to make changes to this QIG or to the product hardware at any time without notice. It is the user's responsibility to determine whether there have been any such updates or amendments herein.

Defects, malfunctions, or failures of the warranted Product(s) caused by damage resulting from unforeseeable incidents (such as lightings, floods, fire, etc.), environmental and atmospheric disturbances, other external forces such as power line disturbances and surge, host computer malfunction and virus, incorrect power input, or incorrect cabling, incorrect grounding and damages caused by misuse, abuse and unauthorized alteration or repair are not warranted.